



# NEWTON GATEWAY

# e-shelf-labels

## TECHNICAL DETAILS



### GENERAL:

Dimensions (mm)	243.0 x 243.00 x 45.57
Model	EGS500DB0X/WWW:
CPU	CortexA9Dual 1.2GHz
Flash Memory	4GB
RAM	1GB
RF MEDEM (IEEE 802.15.4)	2.4GHz & Sub-G
Interface	Ethernet
Power Consumption	10W
Capacity (2.9" BWR)	50,000*1page
Coverage (Indoor in radius)	UP to 30m

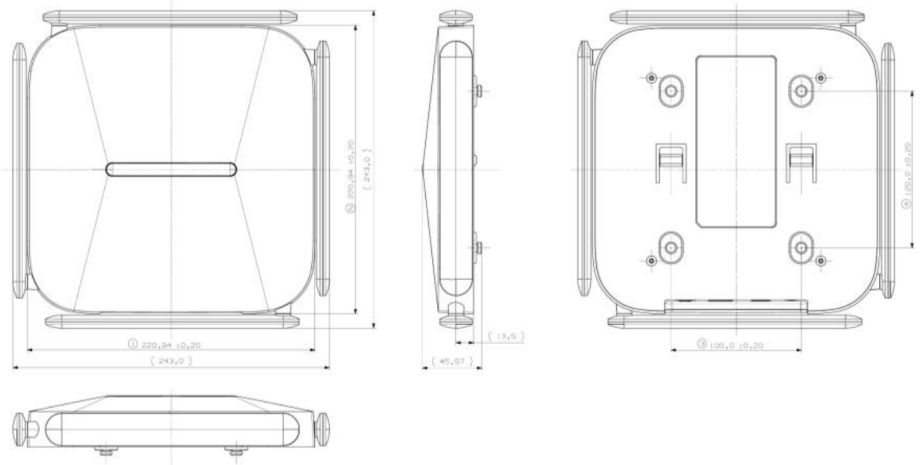

e-shelf-labels | S&K Solutions GmbH & Co. KG

Sailerwöhr 16 | 94032 Passau

+49 (0) 851 / 2099 30 30  
info@e-shelf-labels.com

www.e-shelf-labels.com



brand of solutions